

RZM 15-0400

Technical Data

| RZM 15- | Nominal motor power kW | Poles | Motor size | Motor voltage V | Phases | Nominal frequency Hz | Connection | Nominal motor current A | Nominal motor speed 1/min | Max. fan speed 1/min | Max. operating frequency Hz | Weight kg |
|------------|------------------------|-------|------------|-----------------|--------|----------------------|------------|-------------------------|---------------------------|----------------------|-----------------------------|-----------|
| 0400-4W-16 | 2.2 | 4 | 100L | 230/400 | 3~ | 50 | Δ/Y | 8.1/4.65 | 1455 | 1760 | 60 | 164 |
| 0400-4D-17 | 3.0 | 4 | 100Lb | 400 | 3~ | 50 | Δ | 6.3 | 1425 | 1950 | 68 | 192 |
| 0400-4D-19 | 4.0 | 4 | 112M | 400 | 3~ | 50 | Δ | 8.2 | 1435 | 2160 | 75 | 192 |
| 0400-4D-21 | 5.5 | 4 | 132Sa | 400 | 3~ | 50 | Δ | 11.4 | 1450 | 2390 | 82 | 264 |
| 0400-4D-23 | 7.5 | 4 | 132Ma | 400 | 3~ | 50 | Δ | 15.4 | 1450 | 2650 | 91 | 264 |
| 0400-2D-26 | 11.0 | 2 | 160Ma | 400 | 3~ | 50 | Δ | 21.5 | 2920 | 2970 | 51 | 151 |
| 0400-2D-27 | 15.0 | 2 | 160Mb | 400 | 3~ | 50 | Δ | 29.0 | 2930 | 3300 | 56 | 151 |

Motor code:

- W = Asynchronous motor (efficiency class IE2)
- D = Asynchronous motor

Dimensions in mm, subject to change.

RZM 15-0400

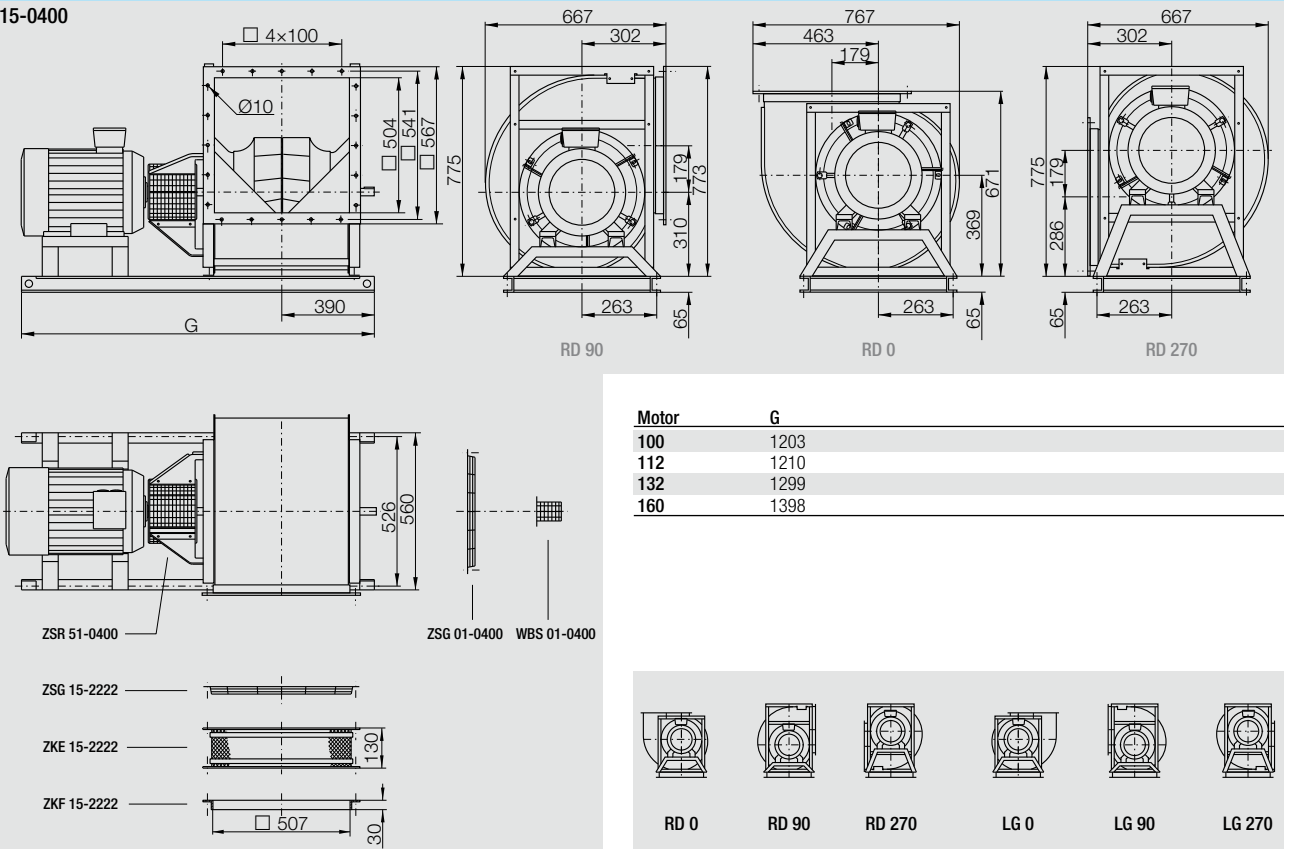

Accessories

| RZM 15- | Frequency Inverter Unit MM420 for 3~ | Line Choke for 3~ | Frequency inverter 6SE6430- | Control Panel for frequency inverter 6SE6420- and 6SE6430- |
|------------|--------------------------------------|--------------------|-----------------------------|--|
| 0400-4W-16 | MM420 3AC 400V 2.20KW EMV B | 6SE6400-3CC01-0BD3 | - | - |
| 0400-4D-17 | MM420 3AC 400V 3.00KW EMV B | 6SE6400-3CC01-0BD3 | - | - |
| 0400-4D-19 | MM420 3AC 400V 4.00KW EMV B | 6SE6400-3CC01-4BD3 | - | - |
| 0400-4D-21 | MM420 3AC 400V 5.50KW EMV B | 6SE6400-3CC02-2CD3 | - | - |
| 0400-4D-23 | MM420 3AC 400V 7.50KW EMV B | 6SE6400-3CC02-2CD3 | - | - |
| 0400-2D-26 | MM420 3AC 400V 11.0KW EMV B | 6SE6400-3CC02-5CD3 | - | - |
| 0400-2D-27 | - | 6SE6400-3CC03-5CD3 | 6SE6430-2AD31-5CA0 | 6SE6400-0BE00-0AA0 |